

C. Knox,

Tool Rest.

No. 102278.

Patented Apr. 26, 1870.

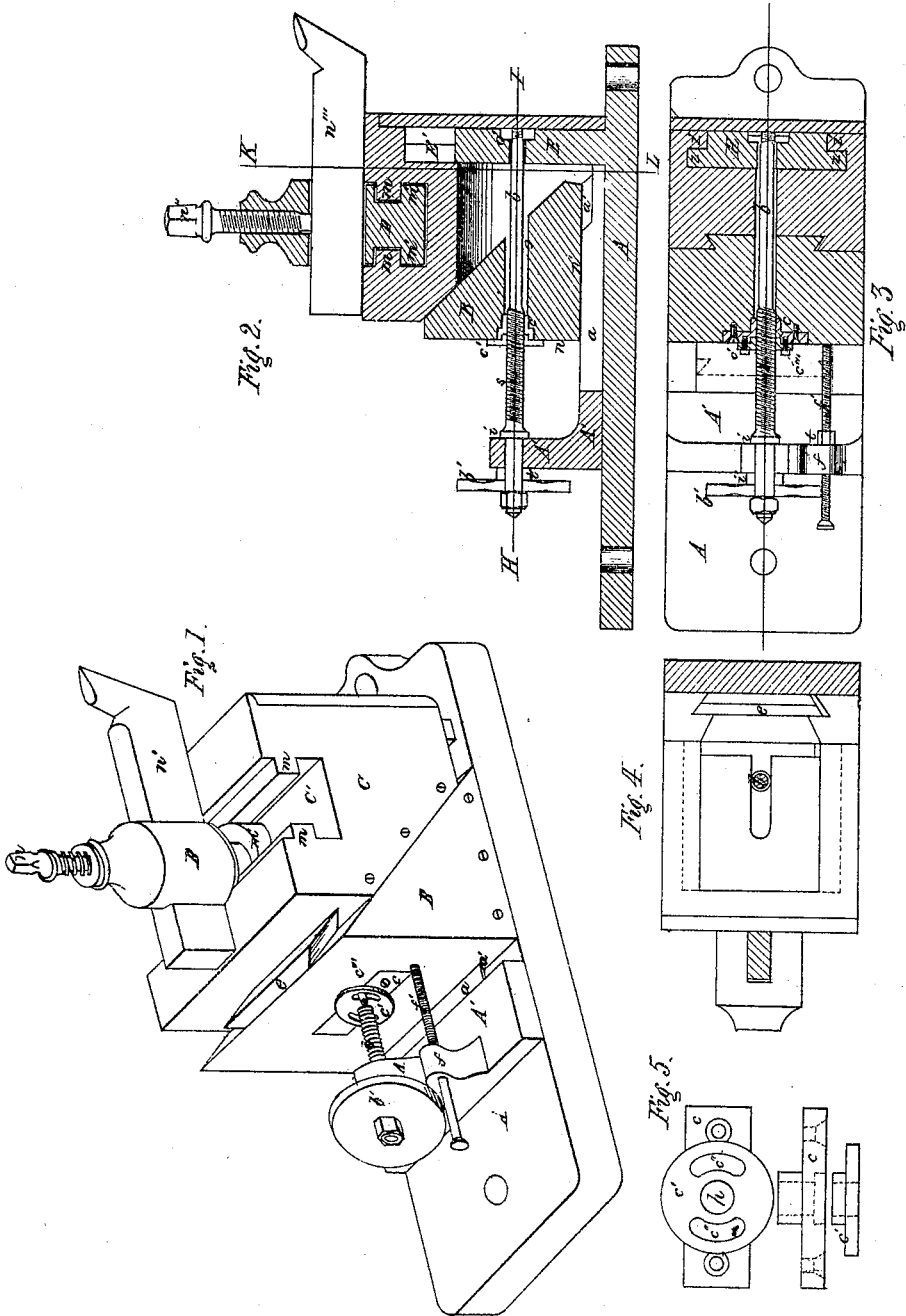

Witnesses.
Wm. L. Bryntson.
C. E. Buckland.

Charles Knox,
Inventor.
By J. A. Curtis
his Attorney.

United States Patent Office.

CHARLES KNOX, OF CHICOPEE, MASSACHUSETTS.

Letters Patent No. 102,278, dated April 26, 1870.

IMPROVED TOOL-ELEVATOR FOR LATHES.

The Schedule referred to in these Letters Patent and making part of the same.

To all whom it may concern:

Be it known that I, CHARLES KNOX, of Chicopee, in the county of Hampden and State of Massachusetts, have invented a new and useful Improvement in Tool-Rests; and I do hereby declare the following, when taken in connection with the accompanying drawings and the letters of reference marked thereon, to be a full, clear, and exact description thereof, and which said drawings constitute part of this specification, and represent, in—

Figure 1, an isometrical view of the device.

Figure 2 is a longitudinal section, in a vertical line with the axis of the operating screw;

Figure 3 is a horizontal transverse section of the device, through line H I of fig. 2;

Figure 4 is a vertical transverse section of the device, through line K L of fig. 2; and

Figure 5 is a front and plan view of the tightening device, for securing the wedge in its desired position firmly.

My invention relates to a device used to elevate and depress the cutting-tool used in the common lathe, and

It consists of an upright part, secured to a bed-piece, upon which upright part operates a block, said block being raised or elevated by means of a wedge driven underneath it; and is depressed by means of a dovetailed projection upon said wedge, which engages into a corresponding channel in the lower part of the block, so that, when the wedge is withdrawn from beneath the block, the said projection draws the block down, while the block is prevented from moving in a horizontal direction by means of the upright post before mentioned.

That others skilled in the art may be able to make and use my invention, I will proceed to describe its construction and the mode of its operation.

In the drawings—

A represents the bed-piece of the device, having thereon the upright part E, each edge of which is chamfered, forming the projections z.

O represents the post-block, in the back end of which is made the cavity E', made to fit properly the chamfered upright part E, and to slide or move thereon in a vertical manner; and said block has its lower front side beveled at C', at about an angle of forty-five degrees, and upon this beveled side is made a dovetail channel, e'.

The wedge B is about the same width as the block C, and has a perpendicular front, n, and a horizontal base, n', and is triangular-shaped in its cross-section perpendicular to the front n, the third side being inclined at an angle of about forty-five degrees, although it will be operative at any other angle of inclination; and in the base n' is a dovetail channel, a', into which fits properly the horizontal dovetail guide portion a.

In the front n of the wedge B is a cavity, into which is inserted a threaded nut, c, or the wedge B being made of metal, the hole o through the wedge may have a thread therein.

The upright part A' has a horizontal hole therein, in which one end of the screw b has its bearing.

The thread s is made upon one portion of the said screw, and also the collar or shoulder i, which, in operating the screw, bears against the inside of the upright A whenever the screw b is turned so that the wedge is drawn toward the said upright A'.

The extreme end of the screw b has a hand-wheel, b', firmly secured thereto, by which to operate the said screw, with a washer or collar, i', between the said hand-wheel and the outside of the upright A'. The other end of the screw b has a bearing in the upright part E.

A check-nut is placed upon the screw b, said check-nut having one or more circular slots, c'', therein, through which passes a screw, by which to secure the said check-nut firmly to the front of the wedge B, or to the nut c, which may be secured therein.

A screw-thread may be made in the wedge B instead of inserting the nut c, as said nut simply furnishes an object to engage with the screw b, so that the wedge B may be drawn out and forced in by turning the screw b.

The check-nut c' has a screw-thread made therein, which engages with the screw b, and the said check-nut is entirely separate from the nut c, so that, when the screw b is turned either in or out to its place, the said check-nut is turned in against the wedge B, and then secured by the small screws passing through the circular slots c''. By means of this check-nut c' the loose motion of the screw b, caused either by its wear or by imperfect construction, may be taken up, so that there will be no movement of the screw, or lost motion of the thread of the screw b, within the nut c.

The part A' has a projection, f, thereon, through which is a threaded perforation, into which is turned the check-rod f', having a screw-thread made thereon; and upon said rod f' is turned the check-nut t. I do not deem it absolutely necessary to the successful operation of the tool to employ both the check-rod and nut f' t and the check-nut c', but I obtain more rigidity by having one operate as a check upon the other.

The upper part of the block O has a transverse channel O' therein, in which are the projections m m, and the tool-post D is of a corresponding form at the lower end, and may slide to and fro in said channel.

The operation of the device is as follows:

It will be seen that, by means of the upright dovetailed part E, or what is the same, the vertical projections z, operating in grooves inside or behind the vertical projections z' upon the block O, said block is free to move in a vertical direction, and in no other,

while the wedge B, by reason of the dovetailed channel *a'* in its base, operating upon the correspondingly-shaped guide-part *a*, which fits into said channel, is free to move in a horizontal direction, and in no other, so that, when the screw *b* is turned into the wedge B, the said wedge is drawn toward the part A', the screw being held from any longitudinal motion by means of its bearing in the part A', and as the wedge B is withdrawn from beneath the block C, and the dovetailed part *e* in the upper part of the wedge B, or upon its inclined side, is drawn out of its correspondingly-shaped socket or groove in the inclined side of the block C, (these two inclined sides upon the block C and wedge B being parallel and operating together, one upon the other,) the said block C is drawn downward in a direct vertical line, and by reversing the movement of the screw or turning it out of the wedge B, the said wedge is forced under the block C, forcing it upward in a vertical direction.

The tool *n'* is inserted in its place in the tool-post D, and by tightening the screw *n* it is firmly secured.

When the tool is raised or depressed to its desired position, the check-nut *c'* is turned up tight and the small screws *c''* tightened, thus preventing any slight backward movement of the wedge B when the point of the tool *n'* enters the iron or metal.

If desirable the check-screw *f'* may also be used by

turning it in against the face of the wedge B, and turning the check-nut *t* back against the bearing *f*. This will still more perfectly prevent any backward movement of the wedge B.

I am aware that various devices have heretofore been used to change the elevation of the cutting tool in a lathe, but never, to my knowledge, has the device herein described been known or used, and I disclaim any and all other devices, irrespective of my construction and arrangement.

Having, therefore, described my invention,

What I do claim as new, and desire to secure by Letters Patent, is—

1. An improved tool elevator, consisting of the blocks C and the wedge B, both having thereon the dovetailed guides *a* and *e*, and the vertical guide E, and operating by means of the screw *b* working in its bearings A', all constructed substantially as specified, and operating to move the tool in a vertical direction, as herein described.

2. In combination with the wedge B and the screw *b*, the check-nut *c'* and set-screws *c''*, for the purposes specified.

CHARLES KNOX.

Witnesses:

T. H. CURTIS,

C. E. BUCKLAND.